

application of shut off valve for power unit in machine room enclosure (1)

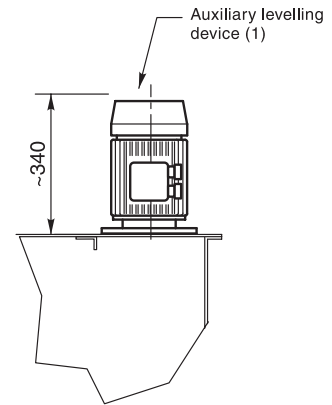
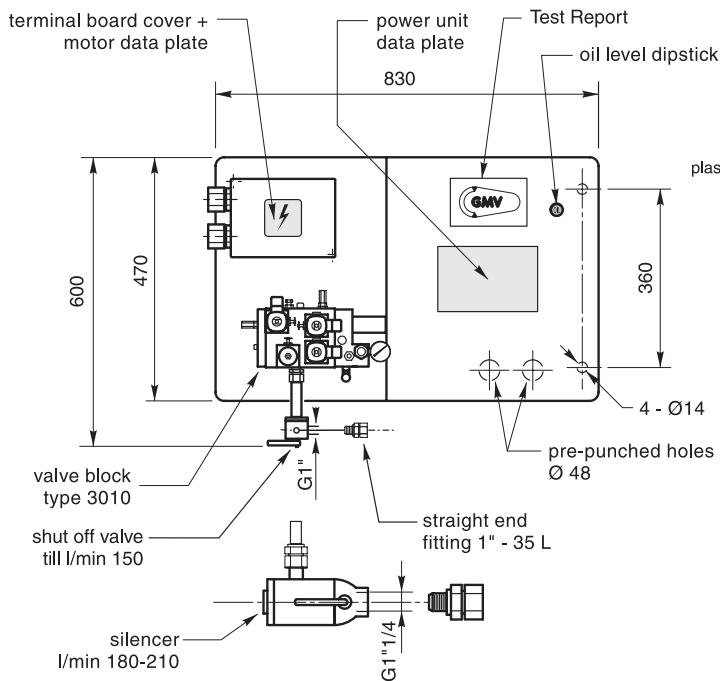
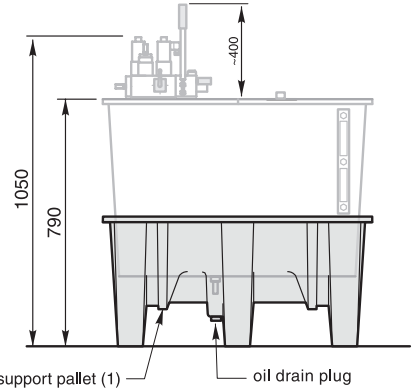

TECHNICAL SPECIFICATION	50 Hz		60 Hz	
	4 poles - 1ph	2 poles - 3ph	4 poles - 1ph	2 poles - 3ph
Motor power [kW]	1,5 ÷ 2,2	2,2 ÷ 14,7	1,8 ÷ 2,6	2,2 ÷ 14,7
Rated pump flow [l/min]	13 ÷ 37	25 ÷ 210	16 ÷ 45	30 ÷ 216
Maximum static pressure [bar / MPa]	45 / 4,5			
dry weight [kg]	max 100			
circulating oil (useful) [litres]	max 90			
Minimum oil volume (motor-pump covering) [litres]	40			

(1) component on request

For information not included in this data sheet please consult GMV